

**PART ROOF PLAN TO SHOW NEW LANTERN LIGHT OVER FLAT 9 BEDROOM**

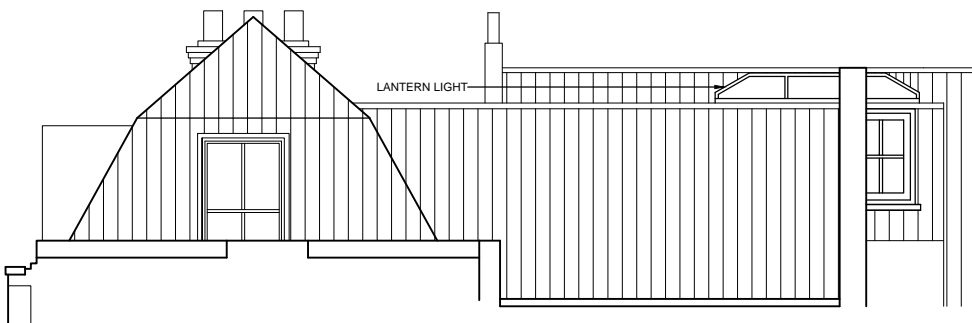

**PART WEST ELEVATION OF ROOF ABOVE FLAT 9 TO SHOW NEW LANTERN LIGHT OVER BEDROOM**

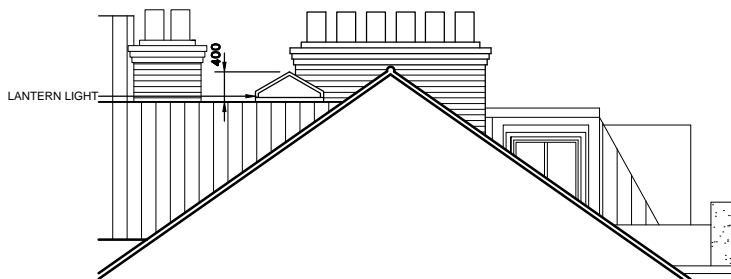

**PART SOUTH ELEVATION ABOVE FLAT 9 TO SHOW NEW LANTERN LIGHT OVER BEDROOM**

This drawing should not be interrogated or scaled – work to given dimensions only.

This drawing must not be copied or reproduced without prior written consent.

The drawing shall be read in strict accordance with all relevant specialists and engineers drawings together with their specifications.

The contractor must check all dimensions on site.

The Contractor, before commencing work on site, must clarify with that the drawing he is working to is the "approved working drawing".

The main contractor shall be responsible for the stability of existing structures and earthworks on the site and adjoining sites and shall take all necessary precautions to safeguard the structures.

All excavations to be approved by the engineer and local authority prior to placing of any concrete.

All trades and materials to comply with the latest B.S. and C.P. standards and local authority approvals as work is completed. All construction to conform with the latest Building Regulations and N.H.B.C requirements.

All electrical, water and gas installations to conform to appropriate regulations and standards of Boards.

REV	DESCRIPTION	DATE
A	AMENDMENT LANTERN LIGHT	22.01.18

CLIENT

JON RILEY ESQ

JOB TITLE

69-71 HIGH STREET  
SOUTHEND ON SEA  
ESSEX  
SS1 1HZ

**as** Architectural Services

19 VICTORIA ROAD, LEIGH ON SEA, ESSEX, SS9 1AU  
Tel : 01702 475095 Mobile: 07885 638467

SCALE	1:100 @ A4	
DRAWN	JAL	DATE NOV 17

AS2102 | 31A

FLAT 9 BEDROOM  
LANTERN LIGHT